

260 SERIES • 12V • MR16



The miniaturized 260 series spotlight is integrated with a low profile fitting that houses an electronic transformer.

- Designed for Tungsten Halogen 2-pin base MR16 lamps up to 75 watts
- Can be configured for use on 120V or 277V systems
- Sturdy aluminum housing
- Removable front hinge assembly allows fixture to be transformed from a spotlight to wall wash fixture in seconds
- Self-locking yoke for horizontal and vertical focusing
- On/off safety switch (on -00 Track fitting)
- Hinged front with relamping handle for easy lamp changing
- Internal multiple accessory clips accept any double combination of size-AAA LSI filters and accessories
- Removable cross-baffle eliminates frontal spill light and glare
- Front rotation lock for alignment of directional accessories
- Lexan track fitting with recessed transformer with Integral 75VA 120V electronic transformer
- Integral clear Pyrex safety shield
- Finishes: LSI Black, White, Silver and Graphite
- Fixture weight: 1.5 lbs.
-  IBEW

MOUNTING OPTIONS

* 260-00

Lexan Fitting for
1 and 2 circuit
LSI Track.
With On/Off switch.

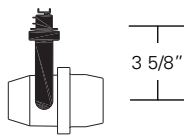

260-5E

Canopy for permanent
mounting on standard 4"
octagonal outlet boxes.
With transformer.



Other Options (Consult Factory):

- Stems, specify length
- Custom color, RAL palette

* Not for use with Unimount or
Emergency/Worklite track.

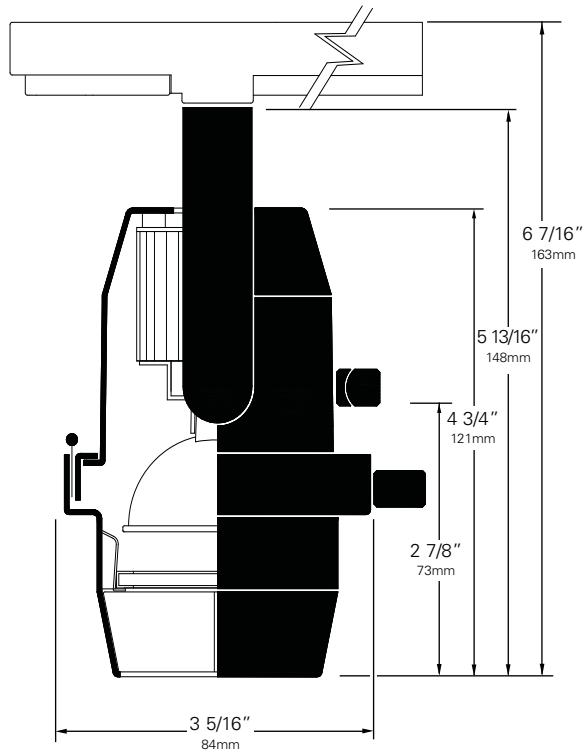

ORDERING INFORMATION

1. Select your **Mounting Option**.
2. If a 277V unit is required, add a **V** before the unit number. Track fitting dimensions slightly larger for 277V.
3. For Wrench Locking, add **WL**.
4. Choose a **Finish** for your fixture:
Black (**B**) White (**W**) Silver (**S**) Graphite (**G**)

Example: **V** **260** - **00** **WL** **B**
277V UNIT FITTURE FITTING WRENCH LOCKING FINISH

Blue fields are optional. Leave blank if not required.

5. Don't forget your **Accessories!**
LSI features the widest range of accessories in the industry to help you modify the light's intensity, color, texture and pattern.

MR16 LAMPS

Watts	Spread	CBCP	
20	7°	7400	Q20MR16/C/VNSP7
20	15°	3750	Q20MR16/C/NSP15
20	40°	525	Q20MR16/C/FL40
35	8°	11000	35MR16/NSP/8
35	20°	3900	Q35MR16/C/SP20
35	40°	1000	Q35MR16/C/NFL40
42	9°	12300	Q42MR16/C/VNSP9
50	15°	9100	Q50MR16/C/NSP15
50	25°	3200	Q50MR16/C/NFL25
50	30°	2500	Q50MR16/C/NFL/30
50	40°	1700	Q50MR16/C/FL40
50	55°	900	Q50MR16/C/WFL55
71	15°	11500	Q71MR16/C/NSP15
71	25°	5500	Q71MR16/C/NFL25
71	40°	2200	Q71MR16/C/FL40

[Click for detailed photometrics](#)

ACCESSORIES



Spread Lenses AAA990, AAA992, AAA995, AAA996

Other accessories:

- Louver Hex AAA
- Glass Color Filters AAA
- Beam Softener AAA998
- Light Blocking Screens AAA801S, AAA802S, AAA803S
- OPTIVEX™ UV Blocking Filter AAA962
- 261FR Entire Wall Wash Front Assembly includes slash front, accessory cartridge, spread lens and kicker reflector.

[Click for complete accessories and descriptions](#)