

**Style F302** 1:10 scale

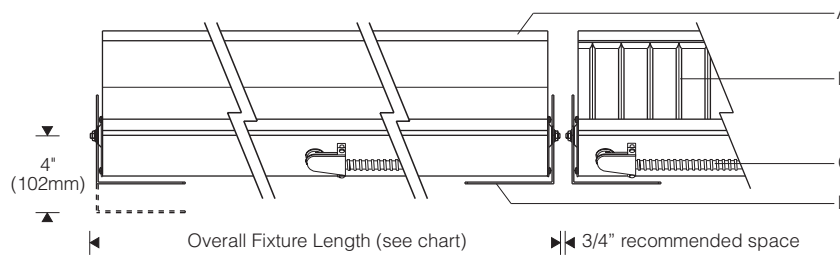

**Cove**

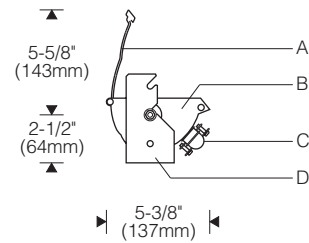
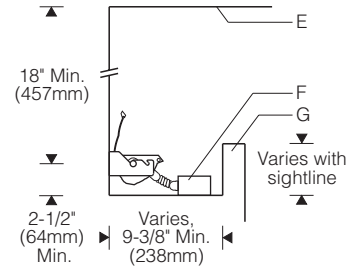

Number of Lamps		Overall Fixture Length
1-Lamp Cross Section	2-Lamp Cross Section	
1	2	25-5/8" (650mm)
2	4	49-3/4" (1265mm)
3	6	73-3/4" (1875mm)
4	8	97-7/8" (2485mm)



Note: Finish interior of cove matte white.

**Specifications**

- A** Specular extruded aluminum reflector
- B** Stamped end plates
- C** Flexible metal conduit with 90° connector
- D** L-shaped 2 position mounting brackets
- E** Ceiling
- F** Remote ballast in aluminum enclosure
- G** Architectural cove (for design guidance, see Applications Section)
- H** Optional snap-in parabolic cross baffle (lengthwise shielding)

**Finish:**

Reflector - extruded high purity aluminum with clear anodized specular finish. Mounting brackets and end plates - formed steel with black powdercoat. Ballast enclosure - mill finish aluminum. All luminaire hardware - stainless steel.

Painted surfaces - 6 stage pretreatment and electrostatically applied thermoset powder coat for stable, long lasting and corrosion resistant finish.

**Mounting:**

L-shaped mounting brackets can be base or wall mounted. Two brackets supplied with each reflector. Two slots in each bracket allow optical center to be positioned either 2-1/2" or 4" from mounting surface. Reflector aiming is adjustable after installation. (When mounting units end to end, allow 3/4" between fixtures to access mounting hardware.)

**Electrical:**

Use 90°C wire for supply connections. 5' (1.5m) wire leads exit front face of reflector. 90° connectors and 4' (1.2m) whips of flexible metal conduit are provided. (2' leads with 1' flexible conduit supplied with dimming ballasts.)

Remote electronic HPF thermally protected class P ballast(s), one-lamp or two-lamp as required. Aluminum ballast enclosures supplied with four 7/8" diameter entries and a knockout for an accessory fuse. **Maximum wire length between ballast and fixture is 9' (2.7m).**

Optional electronic dimming ballast dims to 10% of full light output. **Not available for 55W lamps. Maximum wire length between dimming ballast and fixture is 2' (0.6m).** Compatible dimmer switch is required (by others). Consult local sales representative for specifications.

For complete ballast specifications, see Accessories Section

**Standard:**

UL listed or CSA certified.

**Features**

- **4X** with up to eight 55W lamps per reflector - the most powerful linear fluorescent luminaire available
- Design flexibility for lighting atriums, schools, museums, malls and grand public spaces from concealed locations
- Adjustable aiming - tailor performance to the application
- Electronic ballasts - instant on, quiet, dimming optional

**Performance**

Two parabolic reflector sections drive light across the ceiling from one edge. An elliptical section shields the lamp from normal viewing angles and redirects its light to a parabola. Glare is minimized and asymmetry of the beam is maximized resulting in high beam efficiency and superior surface uniformity.

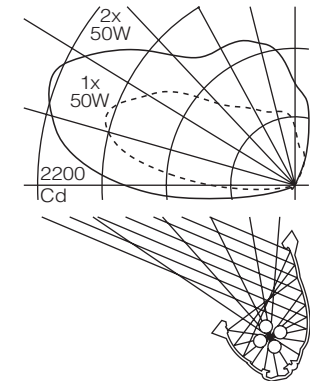

For complete photometrics, visit [www.elliptipar.com](http://www.elliptipar.com)



**To order by Row Code**

When the Style 302 large concealed long twin tube fluorescent is run continuously in **straight** coves, **elliptipar** offers the option of specifying and ordering the entire row as one catalog number. Ordering by row eliminates the need to calculate length, type and quantity of reflectors.

Steps to specify Row Code:

1. Determine clear inside length of cove.
2. Round up to nearest foot and find the nominal row length in chart.
3. If a nominal row length for a given length of cove is not listed, select the next shorter row that is available.
4. Once the nominal row length has been found in the chart, note the actual overall row length (last column).
5. Consider the unlighted length at each end of the row. (Subtract the overall row length from the clear inside cove length, and divide the remainder by two.) It is generally recommended that the unlighted length at each end be between 6" and 12".
6. Determine the number of lamps in the reflector cross section (**L** = 1-lamp cross section, **X** = 2-lamp **4X** cross section) and select the corresponding code.
7. Determine which lamp wattage will be used and select the corresponding lamp wattage codes.
8. Enter the four character Row Code in place of the Lamp Code described on page C-31.1. The remainder of the catalog number is formed as shown on page C-31.1.

**Features**

- Time saving - simplifies specification and ordering
- One catalog number - includes all necessary reflectors, brackets and remote ballasts to install row
- Assured fit - all you need to specify the entire row is the clear inside length of the cove

**3 Row Code**

**Note:** Enter row code in place of Lamp Code described on page C-31.1.

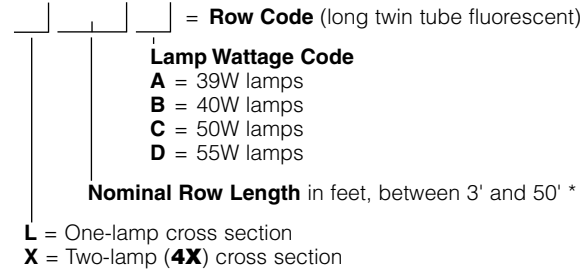

\* Luminaires are in nominal 2' long modules. Nominal rows lengths are not available in every 1' increment (see chart).

Overall row length includes 3/4" clearance between reflectors and at each end of the row for access to mounting hardware.

Nominal row lengths over 50' can be formed by combining shorter row lengths. (Example: a nominal 60' row can be ordered as two nominal 30' rows.)

**Example**

**F302 - X27C - S - 00 - 2 - 000**

Nominal 27' long row of Style 302 large concealed **4X** with two 50W long twin tube fluorescent lamps in cross section. Row includes three nominal 6' long 6 x 50W reflectors, one nominal 8' long 8 x 50W reflector, mounting brackets and remote 277V electronic ballasts. Overall row length is 26' 10-7/8".

Nominal Row Length (feet)	Nominal 2' Reflector (1 lamp in length)	Nominal 4' Reflector (2 lamps in length)	Nominal 6' Reflector (3 lamps in length)	Nominal 8' Reflector (4 lamps in length)	Overall Row Length *
03	1				2' 3-1/8"
05		1			4' 3-1/4"
07			1		6' 3-1/4"
09				1	8' 3-3/8"
11		1	1		10' 5-3/4"
13			2		12' 5-3/4"
15			1	1	14' 5-7/8"
17				2	16' 6"
19			3		18' 8-1/4"
21			2	1	20' 8-3/8"
23			1	2	22' 8-1/2"
25				3	24' 8-5/8"
27			3	1	26' 10-7/8"
29		1		3	28' 11-1/8"
30		1	4		29' 1-1/4"
31			1	3	30' 11-1/8"
32			5		31' 1-1/4"
33				4	32' 11-1/4"
34			4	1	33' 1-3/8"
36			3	2	35' 1-1/2"
38			2	3	37' 1-5/8"
40			1	4	39' 1-3/4"
42				5	41' 1-7/8"
44			3	3	43' 4-1/8"
46			6	1	45' 6-3/8"
48			1	5	47' 4-3/8"
50				6	49' 4-1/2"

\* Overall row length includes 3/4" clearance between reflectors and at each end of the row for access to mounting hardware.

